

## Digital SENSOR

### CTZN : INDUCTIVE CONDUCTIVITY

Inductive conductivity no sensitive to the fouling

- Sensor regulated in temperature
- Ranges 0 to 100 mS/cm or 0-700 mS/cm
- Numerical communication **Modbus** RS-485 and SDI12
- Compact, **robust** and watertight

#### **Applications :**

- Urban wastewater treatment
- Industrial effluent treatment
- Surface water monitoring
- Sea water
- Fish farming

#### **Inductive method :**

A ring-type coil is excited at fixed intervals and the response is retrieved on a second coil, which is linked to the excited coil. The connectivity between the coils (determined by the degree of conductivity) takes place via the conducting solution.

Economic and successful technology that requiring not enough maintenance and not consumable.

#### **Digital Technology :**

The “smart” Digital CTZN sensor stores calibration and history data within the sensor. This allows you a “plug and play” system without re-calibration.

Thanks to the Universal Modbus RS485 protocol, the PONSEL Digital CTZN can be connected to all devices commonly used (Datalogger, Controller, Automat, Remote System...).



### CTZN Specifications :

Measures									
Measure principle	Inductive conductivity sensor regulated in temperature								
Measure ranges conductivity	0,0 – 100,0 mS/cm 0,0 – 700,0 mS/cm								
Resolution	0,1								
Accuracy	< 5% of the reading value								
Measure ranges salinity	0-78 g/Kg								
Working temperature	0 to 50 °C								
Temperature compensation	With CTN or external measure								
Stocking temperature	-10°C à + 60°C								
Signal interface	Modbus RS-485 en standard et SDI-12								
Maximum refreshing time	Maximum < 1 seconde								
Sensor power-supply	5 to 28 volts, max 30 V								
Electric consumption	<b>Automatic Standby &lt; 50 µA , Heating time 100 mS</b>								
	<b>Average Modbus RS485/ Range 0-100 mS/cm</b>								
	<table border="1"> <thead> <tr> <th></th> <th>Vin 5V</th> <th>Vin 12 V</th> <th>Vin 24 V</th> </tr> </thead> <tbody> <tr> <td>1 measure/s</td> <td>31 mA</td> <td>15,5 mA</td> <td>11,5 mA</td> </tr> </tbody> </table>		Vin 5V	Vin 12 V	Vin 24 V	1 measure/s	31 mA	15,5 mA	11,5 mA
		Vin 5V	Vin 12 V	Vin 24 V					
1 measure/s	31 mA	15,5 mA	11,5 mA						
Max curent pulse 700 mA during 2 mS, 350 mA during 150 mS									
Electric consumption	<b>Average Modbus RS485/ Range 0-700 mS/cm</b>								
	<table border="1"> <thead> <tr> <th></th> <th>Vin 5V</th> <th>Vin 12 V</th> <th>Vin 24 V</th> </tr> </thead> <tbody> <tr> <td>1 measure/s</td> <td>22 mA</td> <td>11,5 mA</td> <td>9 mA</td> </tr> </tbody> </table>		Vin 5V	Vin 12 V	Vin 24 V	1 measure/s	22 mA	11,5 mA	9 mA
		Vin 5V	Vin 12 V	Vin 24 V					
1 measure/s	22 mA	11,5 mA	9 mA						

Sensor	
Dimensions	Diameter max. 62,4 mm, Lenght : 196 mm
Weight	700 g
Material	EPDM, PVC, Stainless steel
Maximum pressure	5 bars
Connexion	9 armoured connectors, polyurethane jacket, bare-wires or waterproof Fisher connector
Protection	IP68

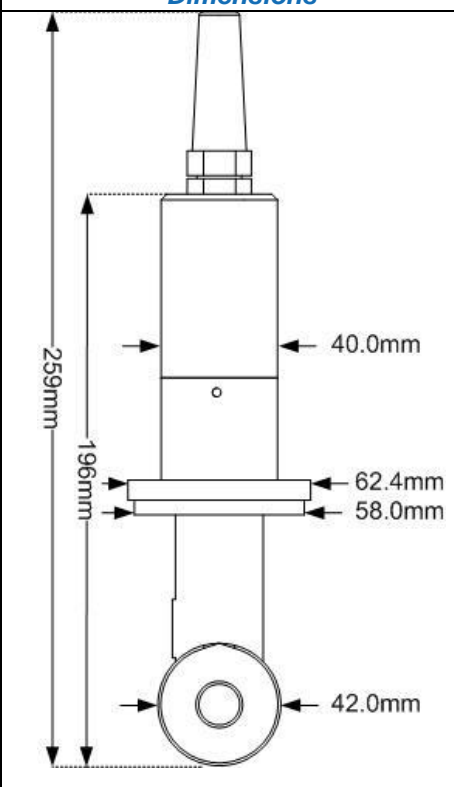
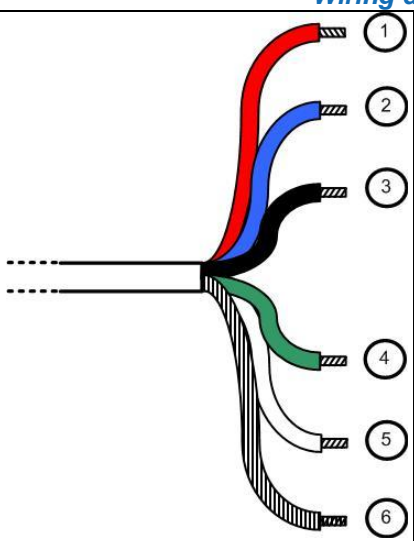
Dimensions	Wiring diagram																												
	 <p><b>Until 15 meters</b></p> <table border="1"> <tr> <td>Red</td> <td rowspan="5">Power supply V+</td> </tr> <tr> <td>Purple</td> </tr> <tr> <td>Yellow</td> </tr> <tr> <td>Orange</td> </tr> <tr> <td>pink</td> </tr> <tr> <td>2</td> <td>SDI-12</td> </tr> <tr> <td>3</td> <td>Power supply V-</td> </tr> <tr> <td>4</td> <td>B " RS-485 "</td> </tr> <tr> <td>5</td> <td>A " RS-485 "</td> </tr> <tr> <td>6</td> <td>Cable shield</td> </tr> </table> <p><b>Cable length up to 15m</b></p> <table border="1"> <tr> <td>1</td> <td>Power supply V+</td> </tr> <tr> <td>2</td> <td>SDI-12</td> </tr> <tr> <td>3</td> <td>Power supply V-</td> </tr> <tr> <td>4</td> <td>B " RS-485 "</td> </tr> <tr> <td>5</td> <td>A " RS-485 "</td> </tr> <tr> <td>6</td> <td>Cable shield</td> </tr> </table>	Red	Power supply V+	Purple	Yellow	Orange	pink	2	SDI-12	3	Power supply V-	4	B " RS-485 "	5	A " RS-485 "	6	Cable shield	1	Power supply V+	2	SDI-12	3	Power supply V-	4	B " RS-485 "	5	A " RS-485 "	6	Cable shield
Red	Power supply V+																												
Purple																													
Yellow																													
Orange																													
pink																													
2	SDI-12																												
3	Power supply V-																												
4	B " RS-485 "																												
5	A " RS-485 "																												
6	Cable shield																												
1	Power supply V+																												
2	SDI-12																												
3	Power supply V-																												
4	B " RS-485 "																												
5	A " RS-485 "																												
6	Cable shield																												