

## DIGISENS RANGE

---

# OPTOD : OPTICAL DISSOLVED OXYGEN

Digital technology for optimized measures

---

- Optical Technology without calibration
- Digital Technology (Modbus RS-485)
- No drift, Reduced maintenance
- Robust, for field applications

### *Applications :*

- Urban wastewater treatment
- Industrial effluent treatment
- Surface water monitoring
- Drinking water



### *Optical technology :*

The **OPTOD**<sup>®</sup> (Optical Dissolved Oxygen technology) is based on luminescent optical technology. The OPTOD sensor is approved by the ASTM International Method D888-05.

Without calibration requirements and thanks to an ultra low power technology, the OPTOD sensor meets the demands of field works and short or long term campaigns.

Without oxygen consumption, this technology allows you an accurate measure in all situation and especially in very low oxygen concentrations

### *Digital Technology :*

The smart+OPTOD sensor stores calibration and history data within the sensor. This allows you a plug and play+system without re-calibration.

Thanks to the Universal Modbus RS485 protocol, the PONSEL OPTOD can be connected to all devices commonly used (Datalogger, Controller, Automat, Remote System ).

**Ponsel OPTOD specifications :**

Measures	
Measure principle	Optical measure by luminescence
Measure ranges	0,00 to 20,00 mg/L 0,00 to 20,00 ppm 0-200%
Resolution	0,01
Accuracy	+/- 0,1mg/L +/- 0,1 ppm +/- 1 %
Response time	90% of the value in less than 60 seconds
Water move	No necessary move
Temperature compensation	Via CTN
Stocking temperature	- 10°C to + 60°C
Signal interface	Modbus RS-485 (standard) and SDI-12 (option)
Maximum refreshing time	< 1 second
Sensor power-supply	5 to 12 volts
Consumption	Standby 25 $\mu$ A Average RS485 (1 measure/ seconde) : 4,4 mA Average SDI12 (1 measure/ seconde) : 7,3 mA Current pulse : 100 mA

Sensor	
Dimensions	Diameter : 25 mm ; length : 146 mm
Weight	450g (sensor + cable 3 meters)
Material	Stainless steel 316L
Maximum pressure	5 bars
Connection	9 armoured connectors, polyurethane jacket, bare-wires or waterproof Fisher connector
Protection	IP68

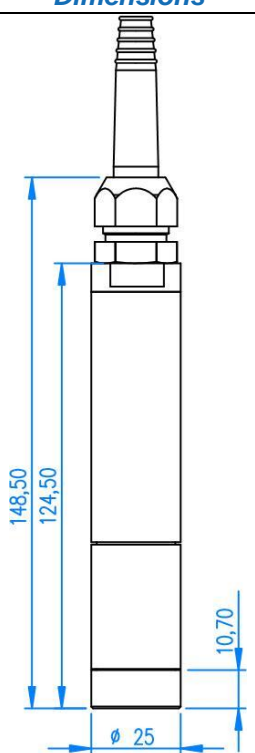
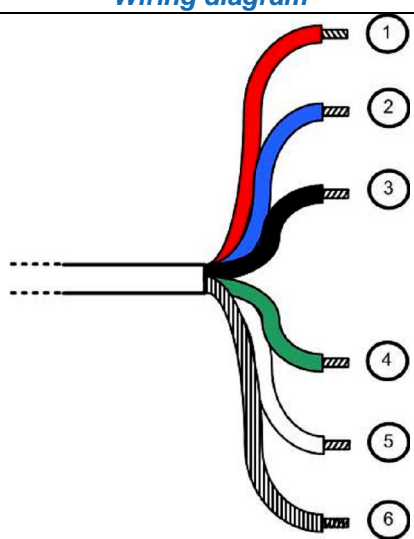
Dimensions	Wiring diagram												
	 <table border="1" data-bbox="1005 1859 1356 2060"> <tr> <td>1</td> <td>Power supply V+</td> </tr> <tr> <td>2</td> <td>SDI-12</td> </tr> <tr> <td>3</td> <td>Power supply V-</td> </tr> <tr> <td>4</td> <td>B " RS-485 "</td> </tr> <tr> <td>5</td> <td>A " RS-485 "</td> </tr> <tr> <td>6</td> <td>Cable shield</td> </tr> </table>	1	Power supply V+	2	SDI-12	3	Power supply V-	4	B " RS-485 "	5	A " RS-485 "	6	Cable shield
1	Power supply V+												
2	SDI-12												
3	Power supply V-												
4	B " RS-485 "												
5	A " RS-485 "												
6	Cable shield												

